

- NOTES:**
 1. MATERIAL:
 2. MAXIMUM ROUGHNESS $\sqrt{32}$ UNLESS SPECIFIED.
 3. REMOVE ALL BURRS AND SHARP EDGES UNLESS SPECIFIED.

SAMPLE END OF "STUBBY" PROBE SHOWN

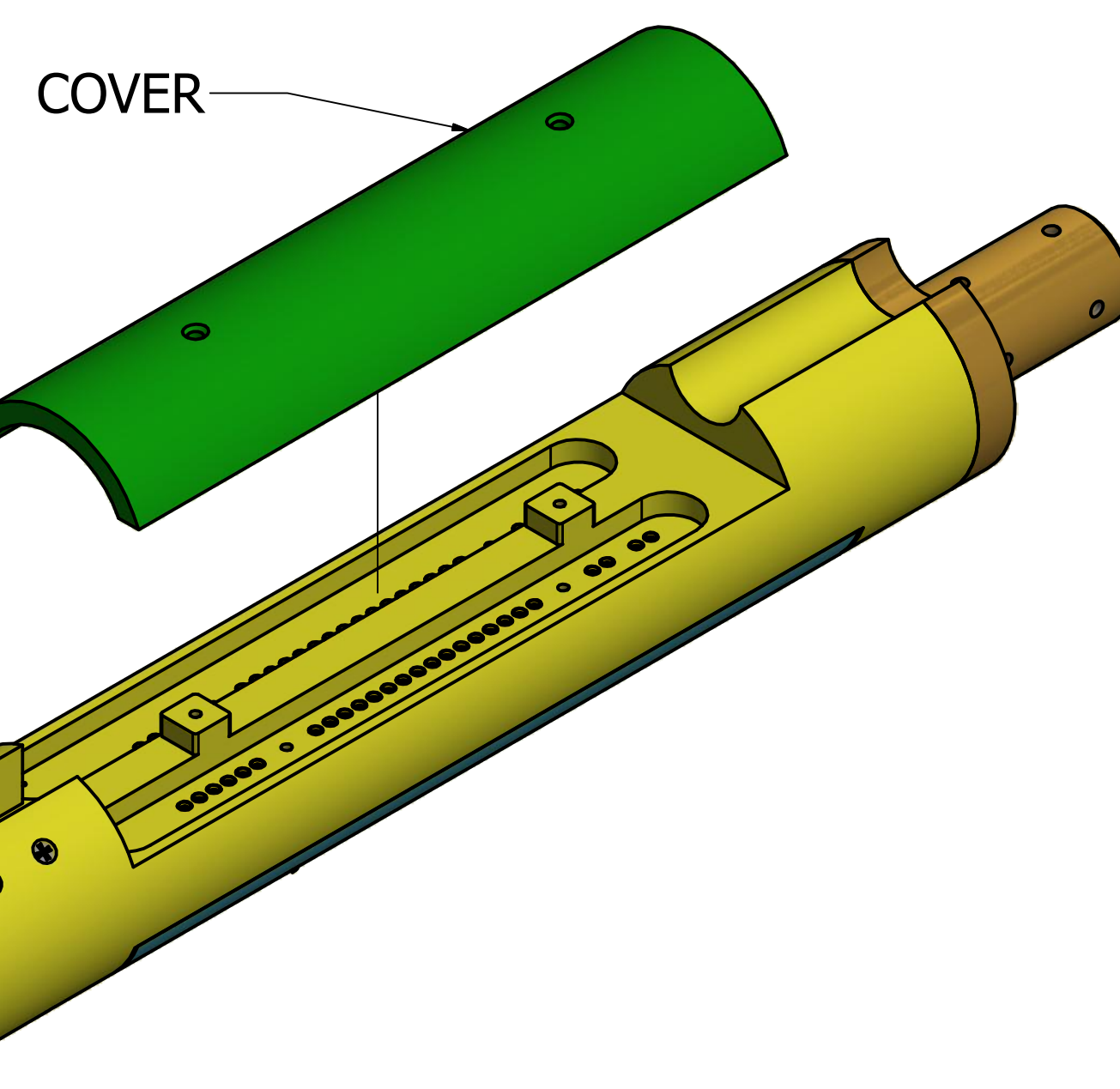

INSTRUMENTATION/SAMPLE CONNECTIONS:
 16 PAIR TWISTED
 38 GA. PhBR
 TERMINATED WITH STANDARD SIP
 SPACED 0.1"

THERMOMETER AND
 HEATER CONNECTIONS

4 PAIR
 S/S COAX
 TERMINATED WITH STANDARD
 SIP SOCKET

THESE DIMENSIONS
 ARE SUBJECT TO CHANGE

FIELD
 CENTER

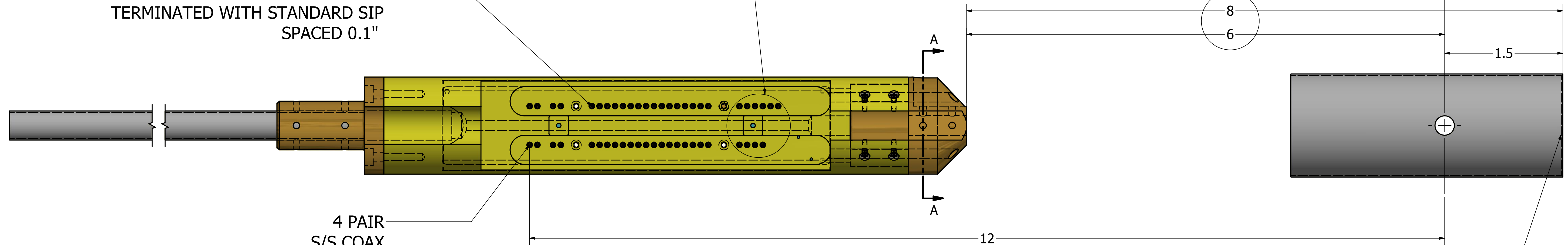

BOTTOM OF 3HE OR
 VTI TAIL

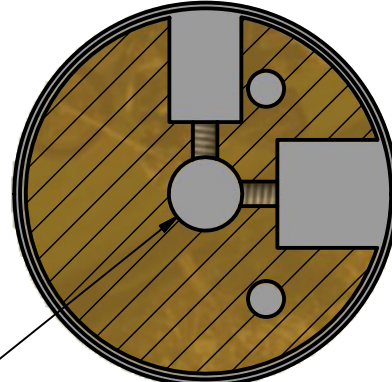

$\varnothing.255$ THRU
 USER CAN MOUNT CUSTOM SAMPLE HOLDER USING
 $\varnothing.25$ TUBE, HELD IN PLACE WITH SET SCREWS

This drawing and the information it contains are both property of the Florida State University and are to be held by the recipient as confidential and are not to be transferred to any third party, used to make or furnish information for making any physical structure or any pictorial, graphic or verbal representation of any information contained herein or copied (unless supplied in productive form) without the express written consent of the Florida State University.

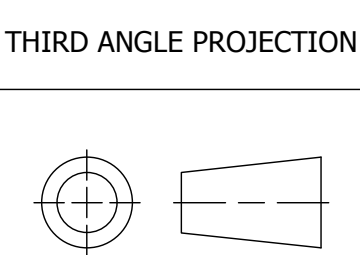

GENERAL TOLERANCES	
1 PL DEC:	± 0.020
2 PL DEC:	± 0.010
3 PL DEC:	± 0.005
ANGLES: $\pm 1^\circ$	

PART MODEL FILENAME SysF_stubby.iam	
MODELED maier	1/5/2018
DETAILED maier	1/5/2018
CHECKED	

NATIONAL HIGH MAGNETIC FIELD LABORATORY
 1800 E PAUL DIRAC DRIVE
 TALLAHASSEE, FLORIDA 32310



SIZE D	DWG NUMBER SysF_stubby	REV
SHT 1 OF 1		